

- 1
- 2
- 3
- 4
- 5
- 6
- 7
- 8
- 9
- 10
- 11
- 12
- 13
- 14
- 15
- 16
- 17
- 18

MATERIAL

Black-oxide steel.

FEATURES AND APPLICATIONS

GN 715.2 eccentric bushings are used to position correctly side thrust pins GN 715 (see page 974). By using the eccentric bushings, the thrust spring pin can be positioned very precisely to adapt to the tolerance of the piece to be machined.

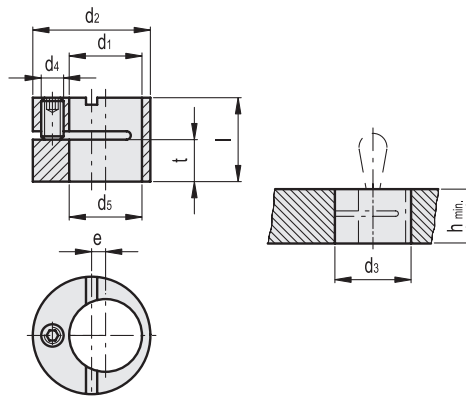
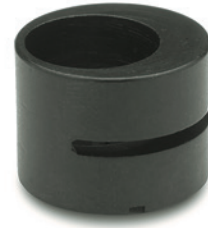

Conversion Table	
1 mm = 0.039 inch	
d1	
mm	inch
6	0.24
10	0.39
12	0.47
16	0.63

METRIC

Code	Description	d1	d2 h9	d3 H7	d4	d5 +0.1	e	l-0.2	h _{min}	t	
GN.37011	GN 715.2-6	6	12	12	M4	6.2	2	9.9	10	4.4	5
GN.37013	GN 715.2-10	10	16	16	M4	10.2	2	11.9	12	5.4	9
GN.37016	GN 715.2-12	12	18	18	M4	12.2	2	13.9	14	6.6	13
GN.37018	GN 715.2-16	16	25	25	M6	16.2	3	17.9	18	7.9	35

Indexing and positioning elements